

Installation Instructions

Anchor Solid Safety Pool Covers

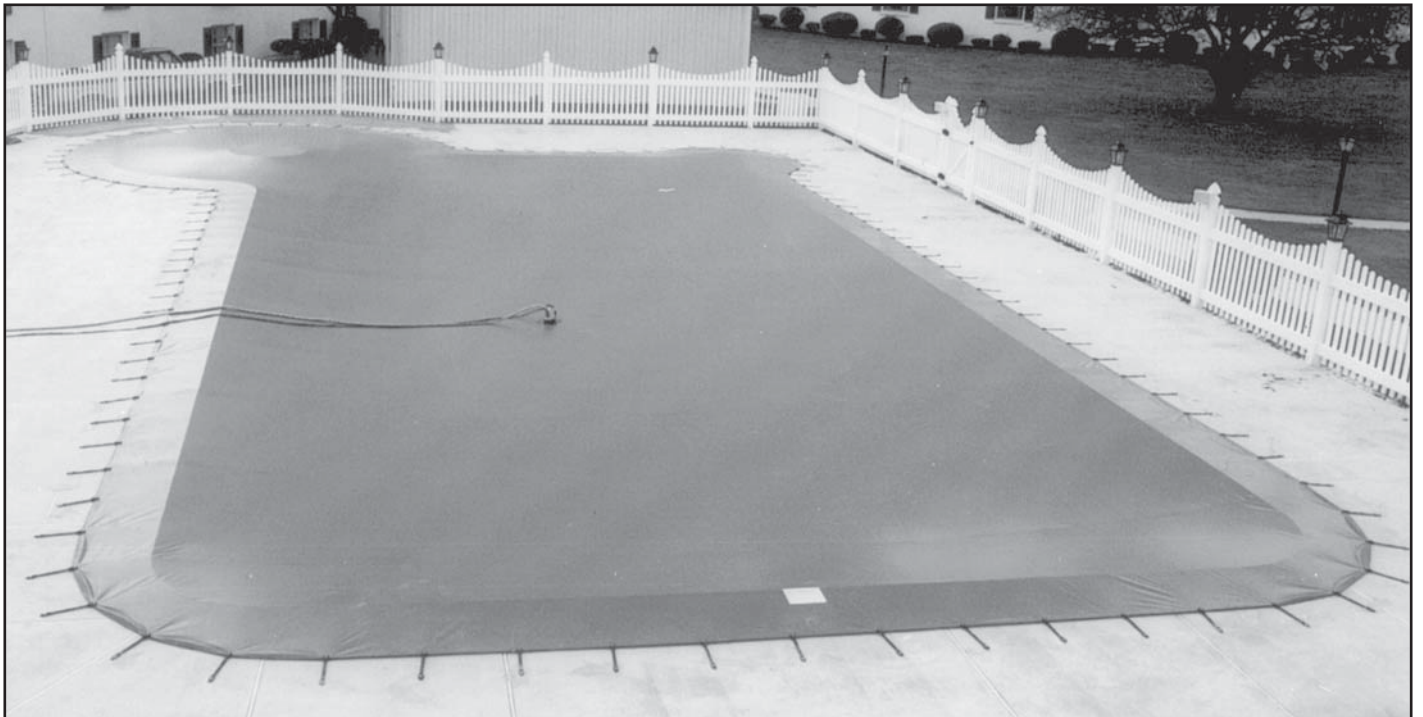

Please read all assembly / installation instructions before the installation or removal of this product.



7701 Highway 41 N
Evansville, IN 47725
Phone: 812-867-2421
Fax: 812-867-1429
1-800-255-5552

email: custdiv@anchorinc.com
www.anchorinc.com

Contents

Warranty.....	3
Introduction, Safety Notes, and Warnings.....	4
Step-1 Tools and Hardware.....	5
Step 2-Prepare Pool for Installation.....	6
Step 3-Placing Cover Over Pool.....	6
Step 4-Aligning Pool Cover.....	7
Step 5-Attaching Rubber Ties.....	7
Step 6-Locating/Setting Brass Anchors and Rubber Ties.....	8
Installation/Removal of Rubber Tie.....	9
Installing Brass Anchors at Corners.....	10
Step 7-Placement of Pump.....	10
Step 8-Inspection and Clean-up.....	10
Step 9-Step Wedges.....	11
Step 9-Step Wedges Continued.....	12
Important Note regarding pool covers with complicated areas.....	13
Optional Cable Assembly Installation.....	14
Optional Cable Assembly Installation Continued.....	15

ANCHOR SAFETY POOL COVER WARRANTY

To whom does the Limited Warranty apply? This Limited Warranty is extended to the original consumer purchaser only, and IS NOT transferable or assignable to any subsequent user of the pool cover.

What is covered by the Limited Warranty? Anchor warrants that the pool cover fabric will be free from defects in materials and workmanship during the Limited Warranty coverage period.

What will Anchor Industries, Inc. do in the event of a product defect? Anchor will repair or replace, at Anchor's sole discretion, the pool cover at no charge at any time during the first twelve (12) months of the Limited Warranty coverage period. After the first twelve (12) months of the Limited Warranty coverage period, Anchor will either, at Anchor's sole discretion, repair the pool cover, or give an allowance towards the replacement of the pool cover. The amount of the allowance will be determined by dividing the number of months remaining in the Limited Warranty coverage period by the total warranty period, and multiplying that percentage times the current dealer price.

How long is the Limited Warranty coverage period? For Mesh pool covers, the warranty period is one hundred and forty four (144) months, beginning on the date of purchase. For Solid and Five-Star covers, the warranty period is one hundred and twenty (120) months, beginning on the date of purchase.

What is not covered by the Limited Warranty? This Limited Warranty DOES NOT cover: (1) replacement of rubber ties, stainless steel springs, or other hardware, (2) damage caused by wear or abrasion at the coping edge, (3) incidental damages to the deck or surrounding surfaces of the pool [see additional limitations on incidental and consequential damages below], (4) damage caused by fire, vandalism, animals or insects, abuse and neglect, improper installation, acts of God, or use for any purpose other than covering a swimming pool, (5) premature deterioration from sun or chemical over-exposure, (6) damage caused by water levels that drop more than 1'-3" below the coping, and/or (7) adjustments to the pool cover not made by the dealer.

What you must do to receive service under the Limited Warranty: Contact your pool cover dealer if you believe there is failure covered by this warranty. The dealer may arrange for inspection of the cover and assist in determining the nature of the problem. You may contact Anchor directly for further instruction regarding the problem and possible resolution. During the first twelve months of the warranty period, Anchor will reimburse for freight charges returning the cover to the factory. You, or your dealer, must obtain Return Goods Authorization (RGA) prior to returning the cover to the factory. Covers returned without prior authorization will be refused and returned at your expense. Anchor will not reimburse freight charges for warranty claims after the first twelve (12) months of the Limited Warranty coverage period. Questions regarding warranty service should be directed to 1-800-255-5552.

LIMITATION OF IMPLIED WARRANTIES

ALL IMPLIED WARRANTIES, INCLUDING, BUT NOT LIMITED TO, ANY IMPLIED WARRANTIES OF MERCHANTABILITY OR FITNESS FOR A PARTICULAR PURPOSE, IN ANY WAY CONNECTED WITH THE SALE OR FURNISHING OF GOODS, THEIR DESIGN, SUITABILITY FOR USE, INSTALLATION AND/OR OPERATION SHALL BE LIMITED TO THE DURATION OF THE COVERAGE PERIOD OF THE LIMITED WARRANTY DESCRIBED ABOVE.

SOME STATES DO NOT ALLOW LIMITATIONS ON HOW LONG AN IMPLIED WARRANTY LASTS, SO THE ABOVE LIMITATION MAY NOT APPLY TO YOU.

LIMITATION OF LIABILITY

BUYER'S SOLE AND EXCLUSIVE REMEDY AGAINST ANCHOR FOR DEFECTIVE OR NONCONFORMING GOODS IS FOR REPAIR OR REPLACEMENT OF DEFECTIVE PARTS OR, AT THE SOLE DISCRETION OF ANCHOR, FOR AN ALLOWANCE TOWARDS THE PURCHASE OF A REPLACEMENT PRODUCT. THIS EXCLUSIVE REMEDY SHALL NOT FAIL FOR ITS ESSENTIAL PURPOSE SO LONG AS ANCHOR IS WILLING AND ABLE TO REPAIR OR REPLACE DEFECTIVE PARTS OR, IN THE SOLE DISCRETION OF ANCHOR, TO GIVE AN ALLOWANCE TOWARDS A REPLACEMENT PRODUCT IN ACCORDANCE WITH THESE TERMS. BUYER AGREES THAT NO OTHER REMEDY, INCLUDING, BUT NOT LIMITED TO, THE RIGHT TO REJECT OR REVOKE ACCEPTANCE OF GOODS, INCIDENTAL OR CONSEQUENTIAL DAMAGES FOR LOST PROFITS, LOST SALES, LOSS OF PRODUCTION, INJURY TO PERSON, DAMAGE TO PROPERTY, OR ANY OTHER INCIDENTAL OR CONSEQUENTIAL LOSS SHALL BE AVAILABLE TO IT AND ANCHOR SHALL NOT BE LIABLE FOR SUCH INCIDENTAL OR CONSEQUENTIAL DAMAGES FOR LOST PROFITS, LOST SALES, LOSS OF PRODUCTION, PROPERTY DAMAGE, PERSONAL INJURY, OR ANY OTHER INCIDENTAL OR CONSEQUENTIAL LOSS ARISING OUT OF THE USE OF OR THE INABILITY TO USE THE GOODS.

SOME STATES DO NOT ALLOW THE EXCLUSION OR LIMITATION OF INCIDENTAL OR CONSEQUENTIAL DAMAGES, SO THE ABOVE LIMITATION OR EXCLUSION MAY NOT APPLY TO YOU. THIS WARRANTY GIVES YOU SPECIFIC LEGAL RIGHTS, AND YOU MAY ALSO HAVE OTHER RIGHTS WHICH VARY FROM STATE TO STATE.

INTRODUCTION:

Thank you for your recent purchase of an Anchor Industries Inc. quality Solid Safety Pool Cover. With proper installation and care, your Solid pool cover will provide protection for years to come.

Every precaution has been taken to ensure that the cover has arrived at its destination without damage. Thoroughly inspect the condition of the containers and note any damage to the freight company at time of delivery.

READ ALL DIRECTIONS BEFORE STARTING

NOTE: The instructions are for a standard installation of shaped and rectangular pool covers. If you have a custom cover, which is not covered in the Installation Instructions, **PLEASE CALL YOUR ANCHOR REPRESENTATIVE FOR ASSISTANCE.**

IMPORTANT NOTE:

Installation of pool cover must begin at any areas with cut-outs or zero tolerance areas (such as at cable-construction). When there are several areas like this, start at most complicated of these areas. See pages 12-14.

SHOULD WARNING LABEL(S) ON POOL COVER BECOME UNCLEAR, PLEASE CONTACT ANCHOR INDUSTRIES FOR REPLACEMENT(S).

WARNING AVOID DROWNING RISK

1. Remove cover(s) completely before entering the pool - entrapment possible.
2. Use the pool cover in accordance with manufacturer's instructions.
3. Remove standing water on solid covers - child can drown on top of cover.
4. Pool covers are not play areas - supervise children at all times.
5. Keep all fasteners in good condition - Inspect regularly - repair or replace any fastener showing wear.
6. Do not walk on cover except in emergency, life-saving rescue situation.
7. Visually inspect condition of fabric for sun or chemical over-exposure resulting in discoloration, brittleness of fabric or broken hardware. This is an indication that cover is no longer a safety cover.
8. Non-secured or improperly secured covers are a hazard.
9. Covers should be stored in an environment that prevents sun, chemical exposure, or access by insects and rodents, and protects cover from tearing or physical damage.

STEP 1: TOOLS & HARDWARE

It is recommended that at least (2) individuals install a cover.

Tools Required For Installation

Rotary Hammer Drill	Several 5 Gallon Buckets
3/4" Masonry Bit	Chalk Line
Tape Measure	Extension Cord (must be "GFCI rated.")
Chalk	
Hammer	

Standard Hardware

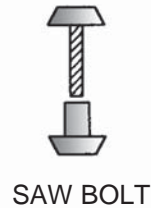
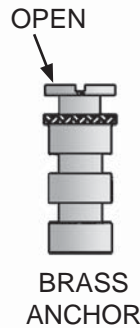
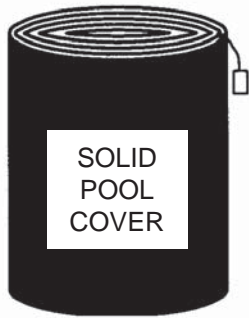

Optional Hardware

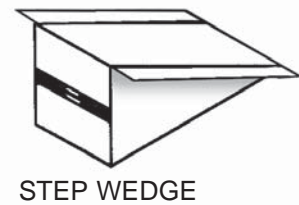
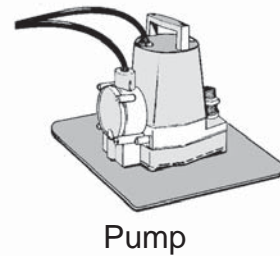
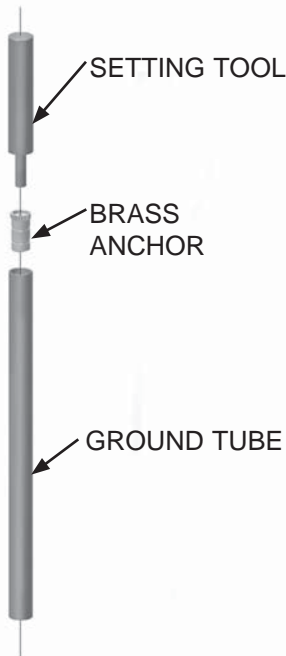

Proper safety equipment should be used at all times to ensure a safe installation. We suggest a careful examination be made to determine safety equipment needed, such as hard hats, steel toe shoes, safety glasses and other as required.

STEP 2: PREPARE POOL FOR INSTALLATION

- 1) It is best to have water level so that there is approximately 15" from pool's edge to where cover rests on water.
- 2) Remove all handrails, ladders, etc.
- 3) Unfold cover onto deck. **DO NOT DRAG THE COVER.**
- 4) Position buckets (filled with water) around pool.

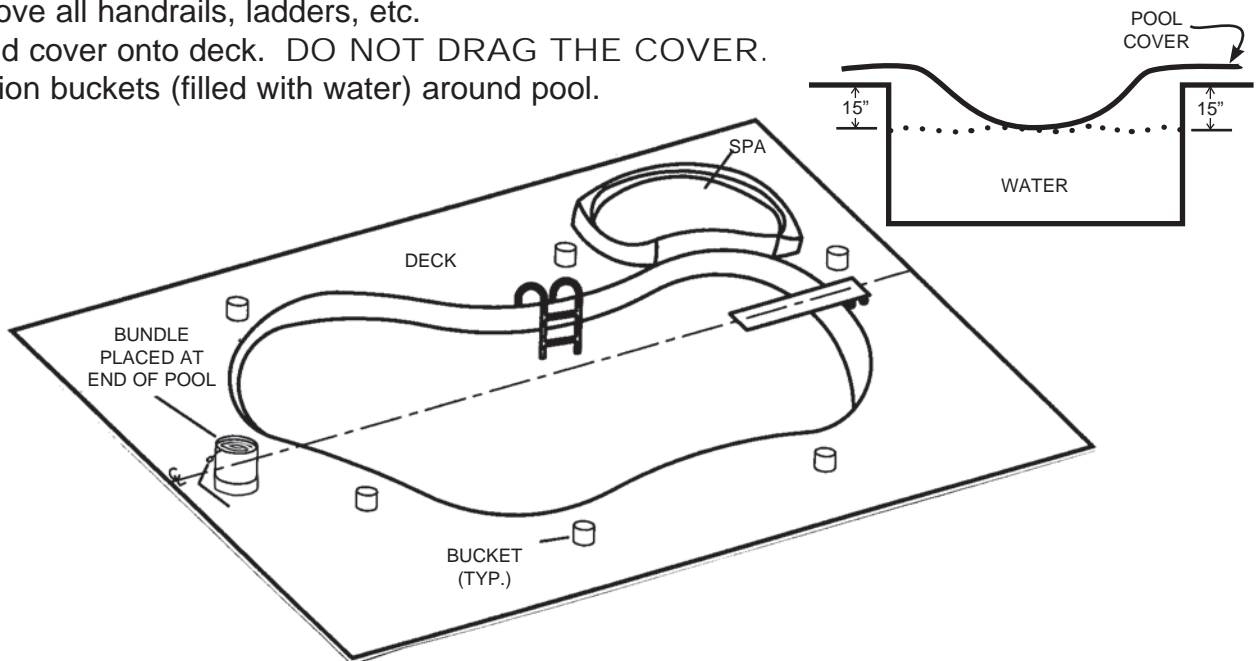

STEP 3: PLACING COVER OVER POOL

- 1) Place bundled cover as shown.
- 2) Unroll pool cover at end of pool as illustrated below. (Black web/hem side down.)
- 3) Install a rubber tie (see Step 5). Position a water bucket on rubber tie at center location.
- 4) Once cover is unrolled, start unfolding cover towards opposite end and place water buckets on rubber ties across from each other. Continue doing this until pool cover has completely covered pool.

NOTE: Do not place water buckets on cover, damage may occur. Place water buckets only on ties.

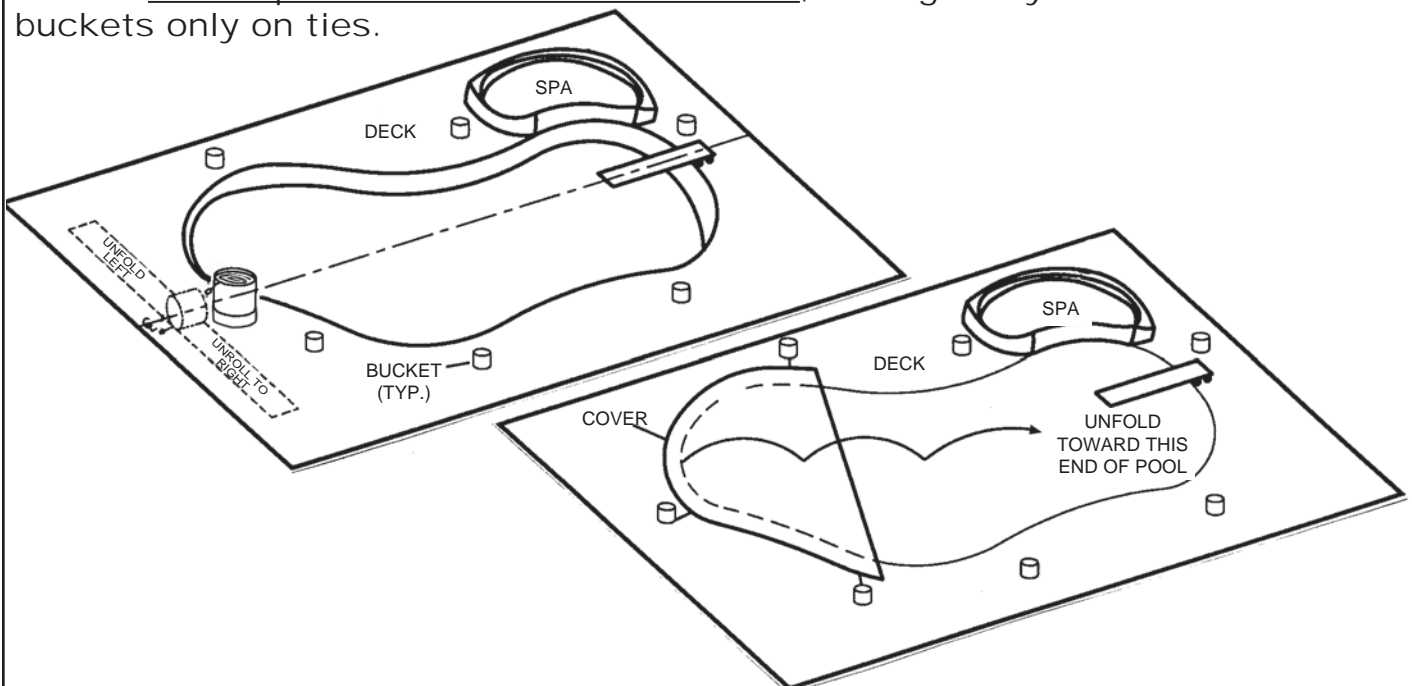

STEP 4: ALIGNING POOL COVER

- 1) Once cover is unfolded across pool, line up cutouts for ladders, slide legs, etc. and/or cable areas, be sure the cover aligns properly with these objects first. **See important note page 12.**
- 2) Reposition cover to equal the overlap all around pool edge.
- 3) If cable is needed, see Optional Cable Assembly Installation Instructions (pages 13 & 14). Otherwise, proceed to STEP 5.

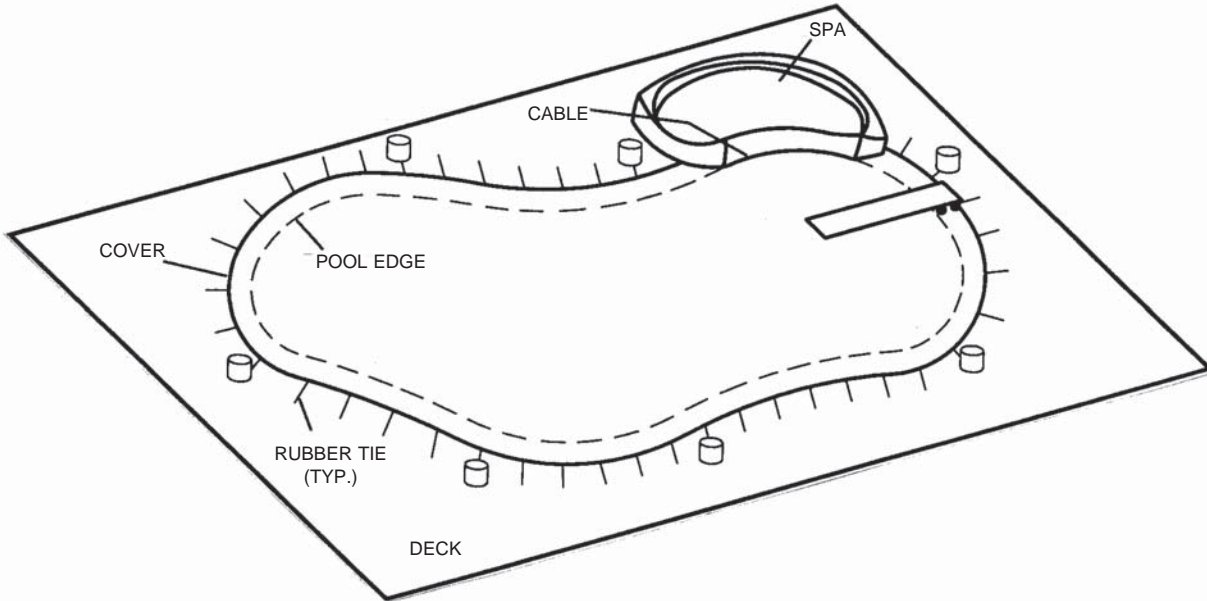

STEP 5: ATTACHING RUBBER TIES

- 1) Attach rubber ties around cover.
- 2) Take the split connection end of the rubber tie, align holes with grommet (around outer edge of cover) and attach with saw bolt. See illustration below.

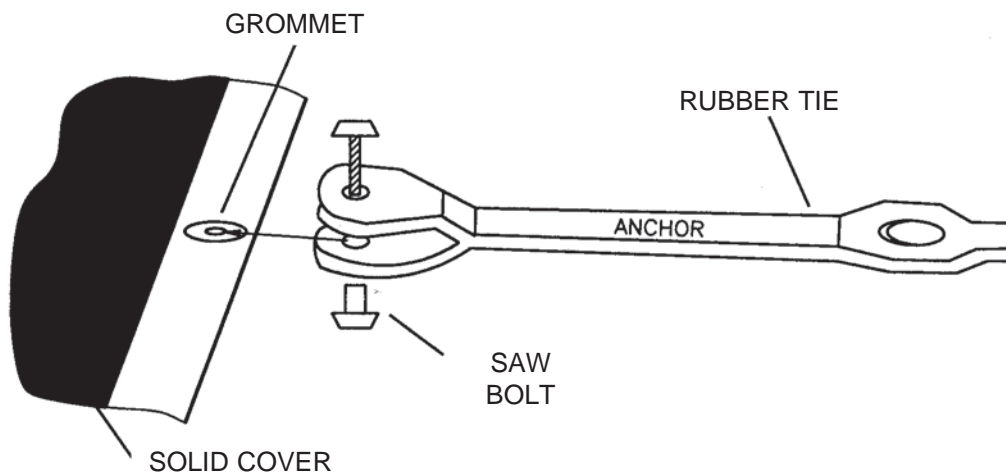

STEP 6: LOCATING/SETTING BRASS ANCHORS & RUBBER TIES

1) Brass anchors are placed approximately 11" from pool cover edge.

1a) Rectangular Pool Covers: Start with center strap of pool's length. See *NOTE below. Mark for brass anchor location (use chalk). Drill hole and set anchor, see FIG. 1. Attach end of rubber tie, see Fig. 2A. Repeat on opposite end. Go to center grommets of the pool's width and repeat the same procedure. Now work from center straps (width and length) toward corners alternating side to side (do not begin with corner straps). Once you have set brass anchors and fastened rubber ties, go to corners and set brass anchors. Brass anchors should be over 1" from 90° corner, see FIG. 3.

1b) Shaped Pool Covers: Start with center strap of pool's length. See *NOTE below. Mark for brass anchor location (use chalk). Drill hole and set brass anchor, see FIG. 1. Attach rubber tie to brass anchor, see FIG. 2A. Repeat on opposite end with center strap. Go to center grommet of the pool width and repeat the same procedure. Now start working around your cover. Remember to set brass anchor and fasten strap across from each other as you work around the cover.

*NOTE: Before setting any brass anchors, check to see if there are obstructions such as diving boards, rocks, etc. at center web location. If there is obstruction at center web, start with nearest web on either side.

DRILLING HOLES FOR BRASS ANCHORS

- 1) Drill holes no more than the depth of the brass anchor (1 5/8"). **Do not over-ream the diameter of the hole. If this does happen, apply a masonry anchor adhesive to the brass anchor before setting into hole. (Note: clean hole out before setting brass anchor).
- 2) With screw removed (using 3/16" allen wrench), place brass anchor into hole. With a hammer and setting tool, firmly tap brass anchor into hole.
- 3) Brass anchor should be flush with deck.

**NOTE: For best results, use a sharp masonry bit and a high-speed rotary hammer drill to reduce chipping. If chipping still occurs, use flanges with brass anchors (available on request) to cover these areas.

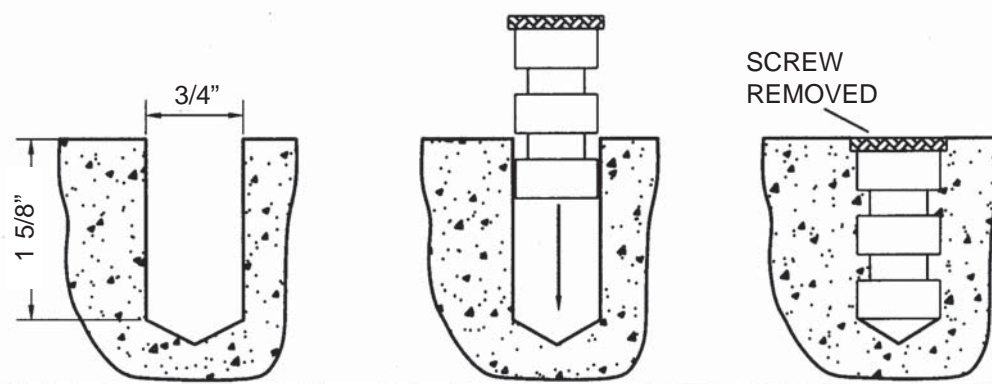
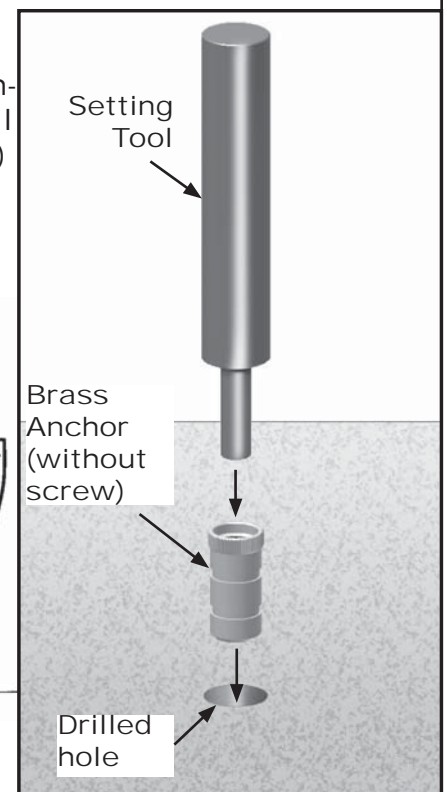

FIG. 1



INSTALLATION/REMOVAL OF RUBBER TIE

INSTALLING

- 1) When fastening tie, brass anchor screw should be in open position (unscrewed approximately 1/2"). Take end of tie and place onto brass anchor. Pull the rubber tie to the anchor and slip the tie over the open anchor. Then let the tie slide onto the anchor for secure fit.

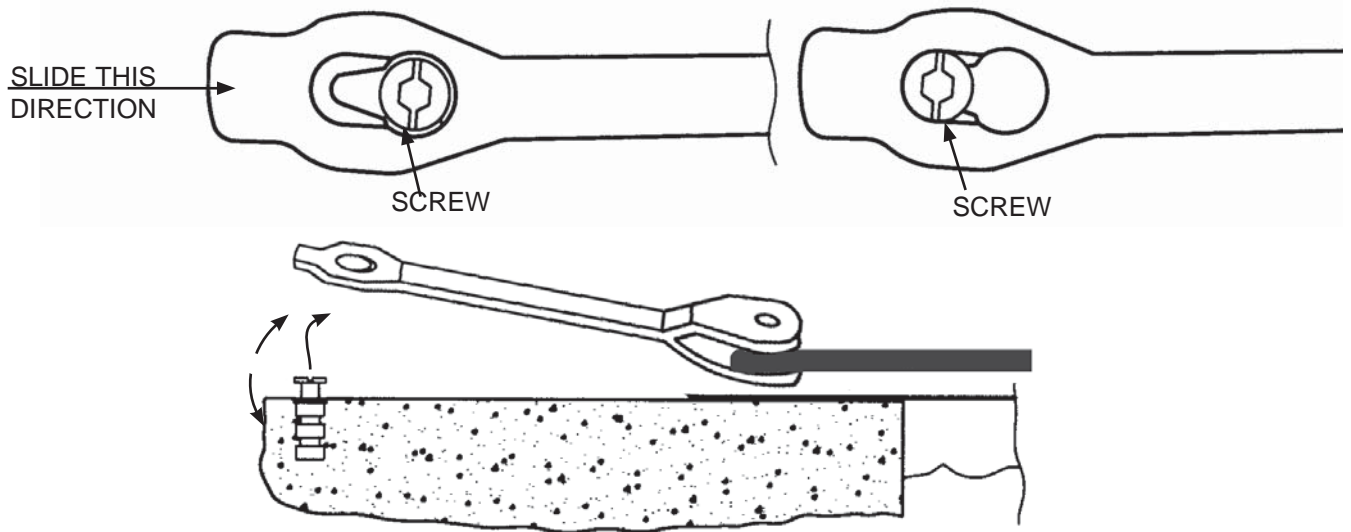

FIG. 2A

REMOVAL

- 1) To remove, reverse operation of installing. Pull rubber tie until it slides out of groove and lift up.

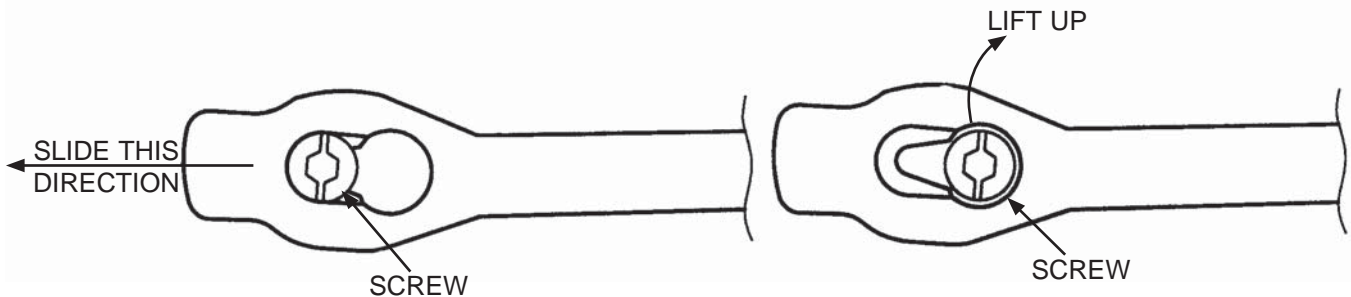

FIG. 2B

INSTALLING BRASS ANCHORS AT CORNERS

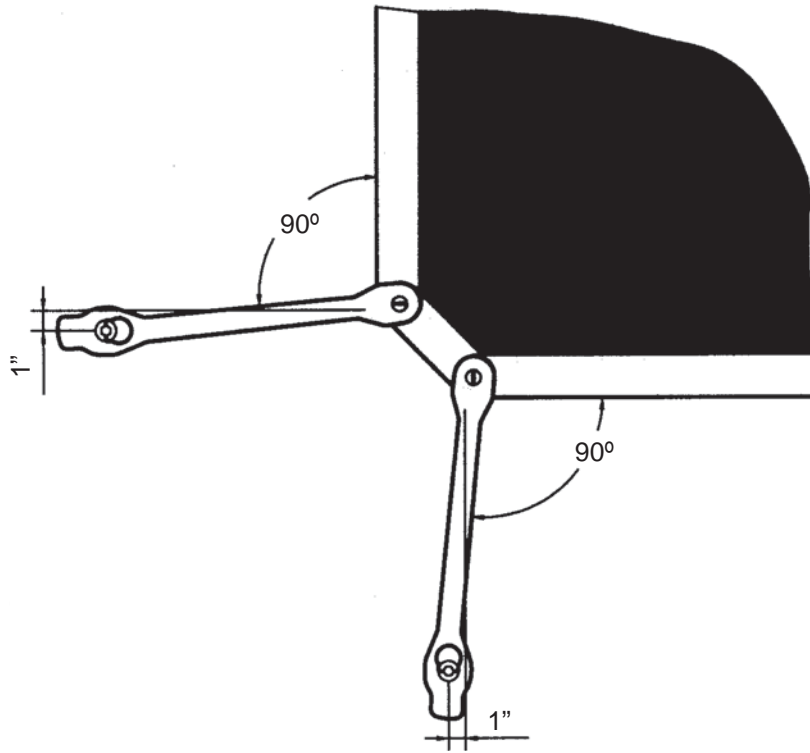
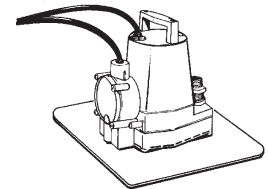

FIG. 3

STEP 7: PLACEMENT OF PUMP

Place pump onto the cover at the geographical center of the cover. The pump rating must be 1200 gph or more. The cover will present a hazard and will not meet safety cover criteria without a pump.



STEP 8: INSPECTION AND CLEAN-UP

1) After the cover has been installed, look for any area (besides that reinforcement attached to the cover during manufacturing) that may need protective padding on the underneath side of cover. On site padding may consist of carpeting, vinyl liner remnants, etc.

Complete the installation by sweeping any concrete dust.

Deliver the door knob pack with warranty and user information to the homeowner.

CALL ANCHOR POOL COVER SALES @ 1-800-255-5552
TO CLARIFY INSTALLATION INSTRUCTION QUESTIONS.

STEP 9: STEP WEDGES

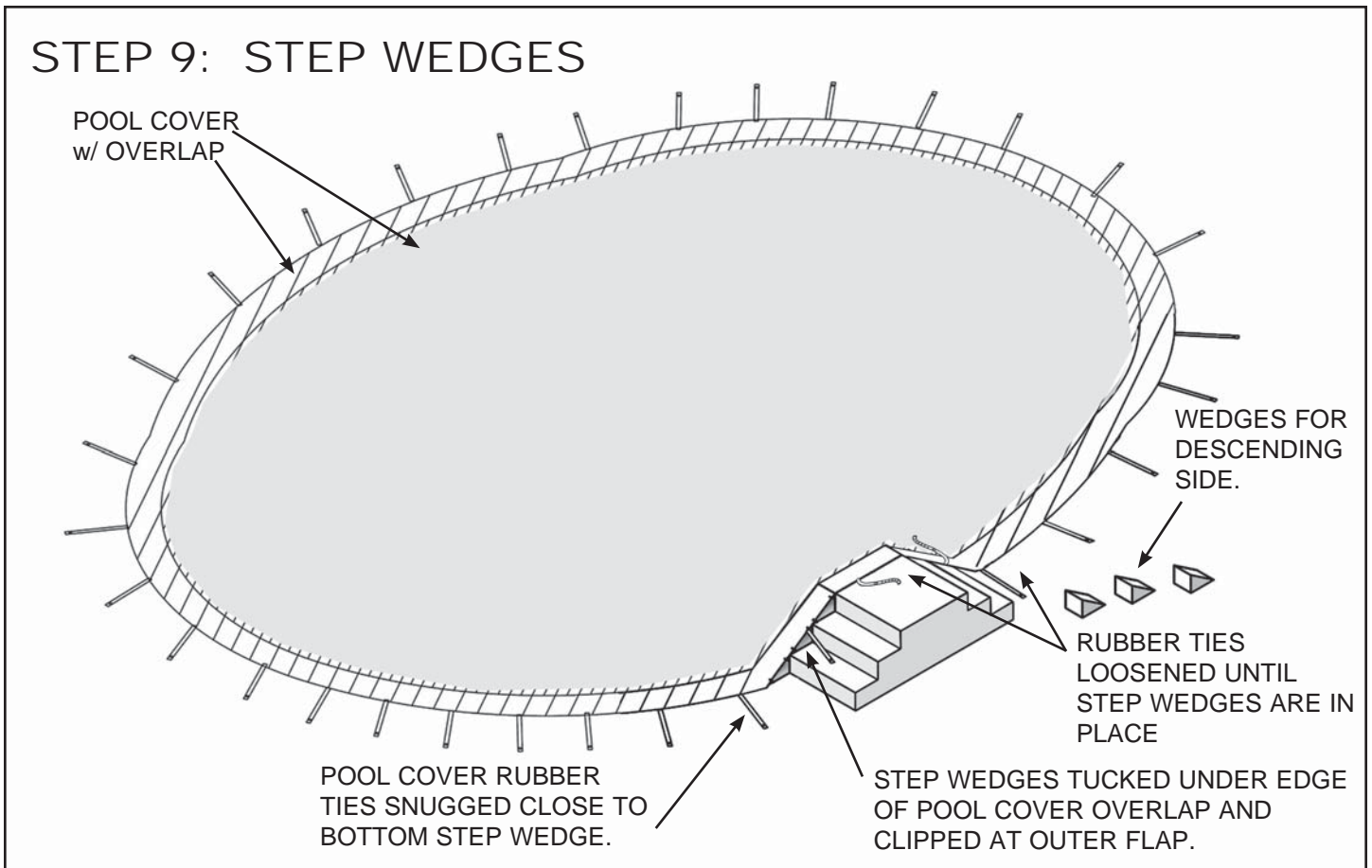

INSTALLING STEP WEDGES

1. Before tightening the pool cover anchors near the steps, tuck step wedges under the overlap edge of the cover, as needed.
2. Pull the outer edge of the cover to the outside flap of the wedges and clip the flap to edge of the cover using the clips for step wedges provided.
3. Install the rubber ties and anchors to tighten the cover.
4. Be sure that the last rubber ties near the top and bottom steps are snugged up close to the wedge to secure it firmly in place.
5. Step Wedges come in standard sizes of 14" and 28" (measured on the horizontal dimension along the step). Custom sized wedges can be made upon request.

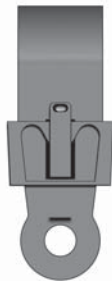

CLIP FOR
STEP
WEDGES

STEP 9B

COMPLETE STEP COVERING,
WITH WEDGES IN PLACE AND
RUBBER TIES INSTALLED TO
SECURE THE COVER.

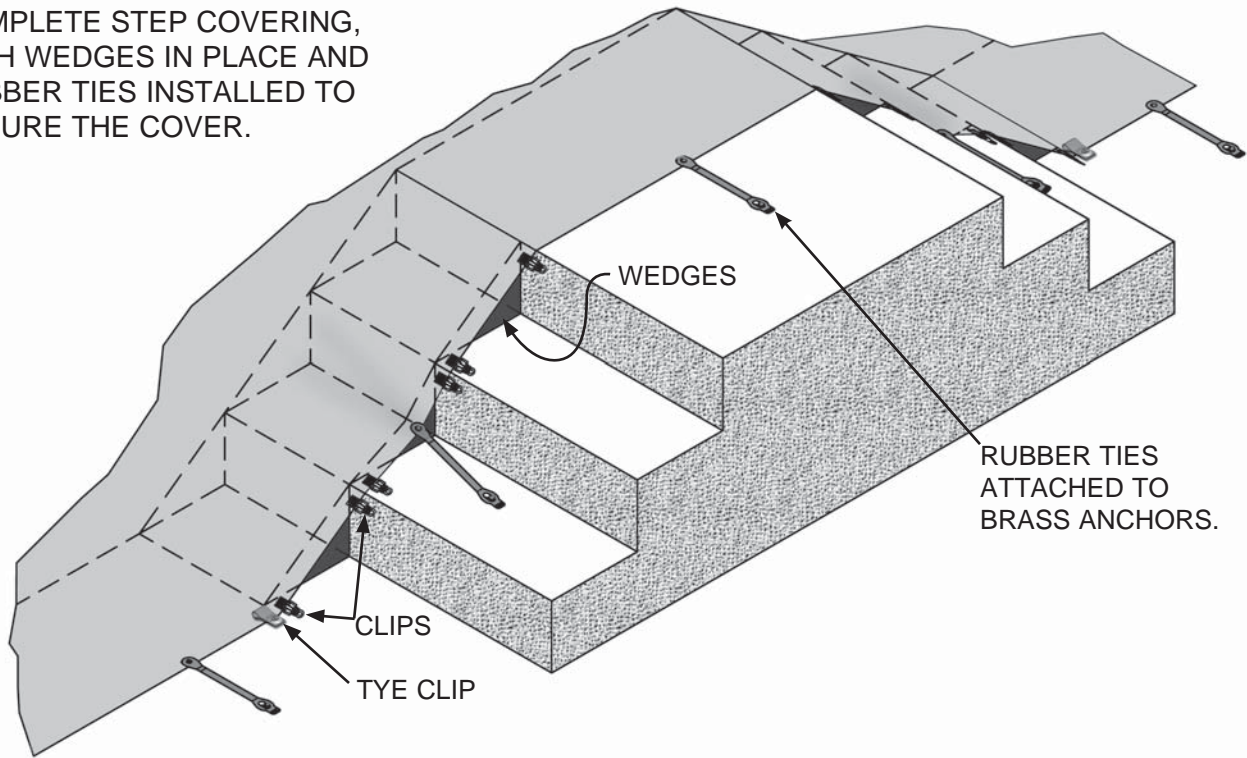

STEP 9C

FLAPS FOR
CLIPPING
TO COVER

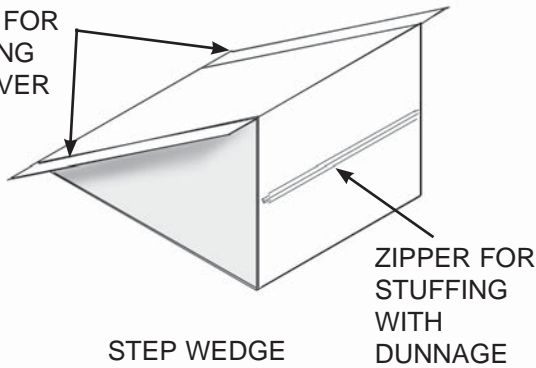

TYE CLIP INSTALLATION

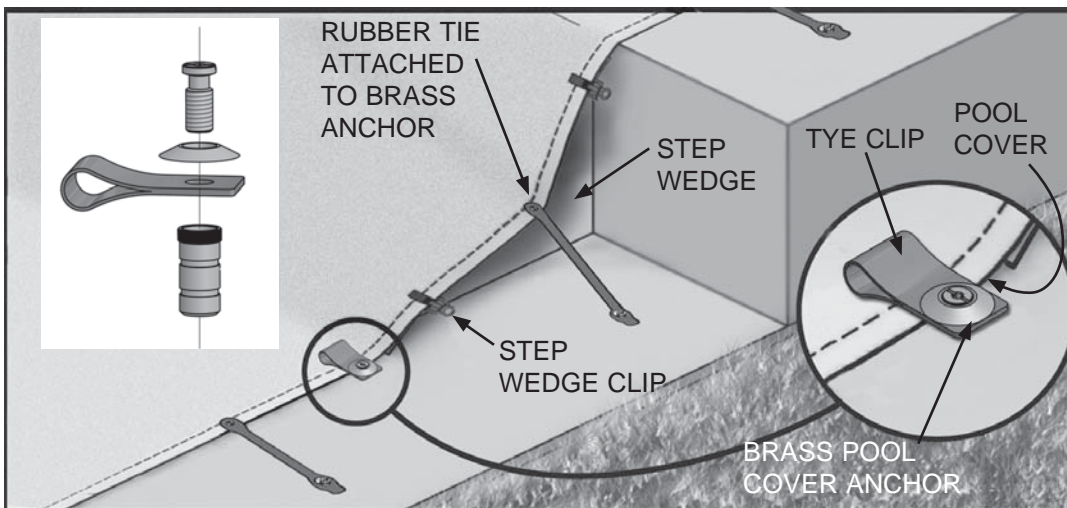

- Determine best placement for Tye Clip Assembly.
- Install Brass Anchor butted up next to edge of pool cover.
- Assemble the Tye Clip as shown in drawing to the left.
- Catch pool cover beneath the black or white Poly Strip. (See drawing to the left)

IMPORTANT NOTE:

Installation of pool cover must begin at any areas with cut-outs or zero tolerance areas (such as at cable-construction). When there are several areas like this, start at most complicated of these areas.

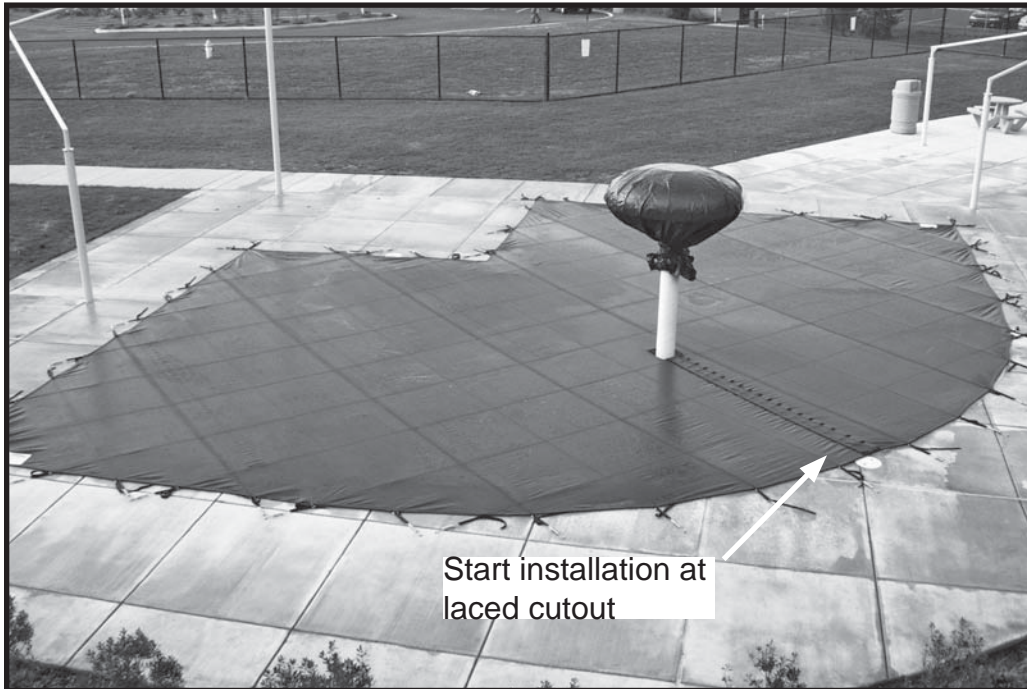

OPTIONAL CABLE ASSEMBLY INSTALLATION

IMPORTANT NOTE:

This application is for a standard straight wall installation. A custom shaped cable area's bolt spacing for an inside radius section of a raised wall will require a narrower spacing than a straight wall. Contact your Anchor representative for assistance in defining the requirements.

INSTALL CABLE HARDWARE AT THE SAME LEVEL AS THE REST OF THE COVER!

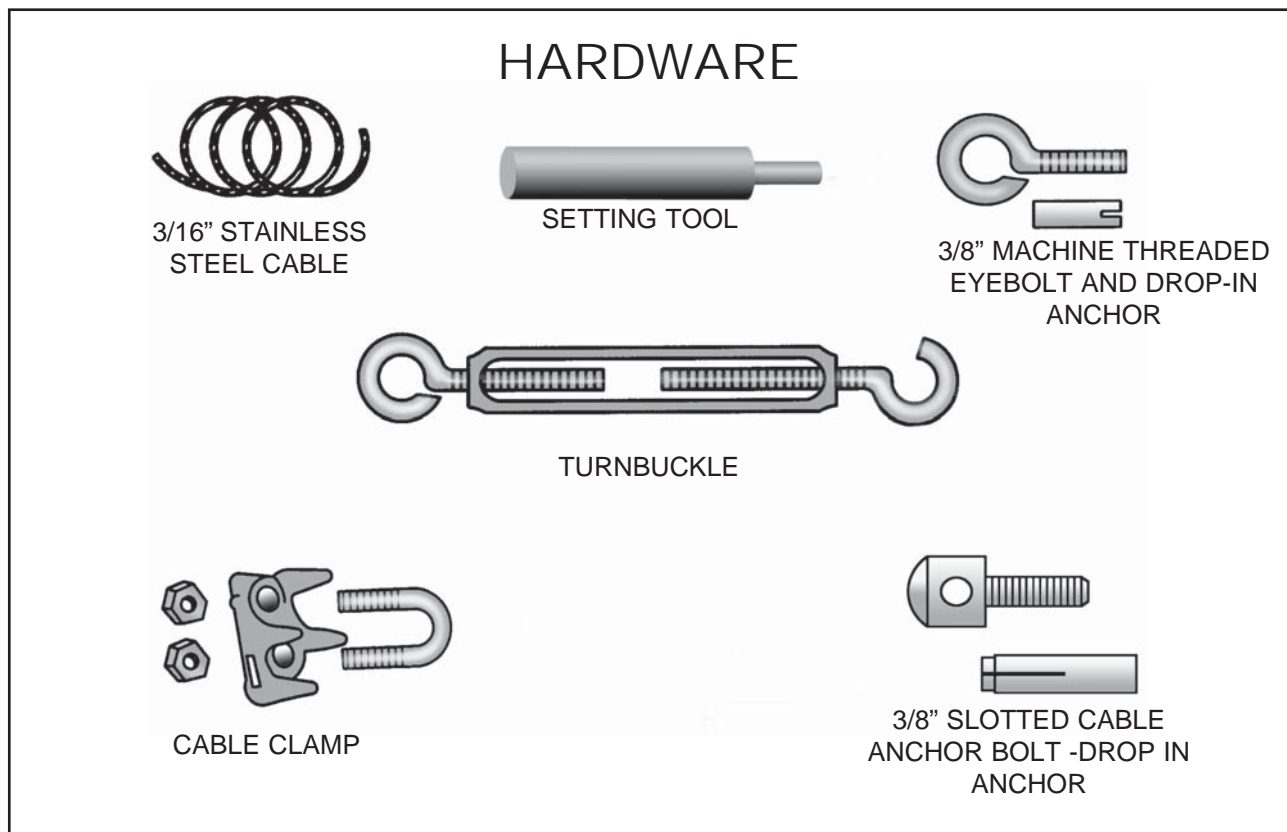

1) Install 3/8" drop-in anchor with 3/8" eyebolt on one end of cable area. Install 3/8" drop in anchors at the opposite end of the cable area and approximately 18" apart for the 3/8" cable anchor bolts. See FIG. 4

2) When installing the cable anchor bolt to the cable area, align the hole in the anchor bolt in the direction of the cable. See FIG. 5A. Run the cable through the in-line holes. See FIG. 5B. Run one end of the cable through the cable anchor at one end of cable area and loop. Attach (2) cable clamps and tightly secure cable, see FIG. 5A. Run other end of cable through eyebolt on turnbuckle, make loop and attach (1) cable clamp for now. With turnbuckle fully extended out, attach hook end of turnbuckle to the eyebolt at the end of the cable area. Loosen the (1) cable clamp and pull cable as taut as possible. Tighten (1) cable clamp and add second cable clamp now. Be sure all cable clamps are tight to secure the cable. Rotate mid-section of turnbuckle to tighten cable further, see FIG. 5C.

3) Attach the snaps located under pool cover in cable area onto cable. See FIG. 5D.

OPTIONAL CABLE ASSEMBLY INSTALLATION - cont'd

FIG. 4

Drilling/Setting of 3/8" Drop-in Anchors

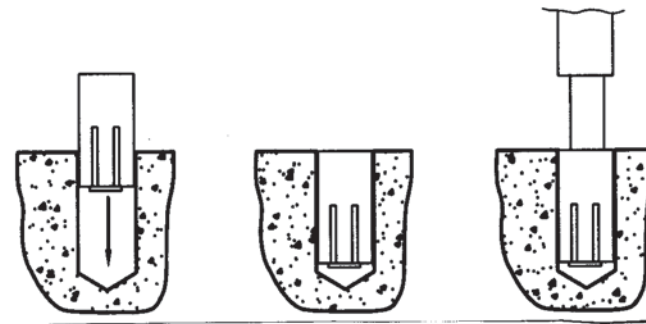

EMBEDMENT
 3/8" Drop-in
 Drill Diameter - 1/2"
 Minimum Depth - 1 7/8"

1) Drill a hole into base material to the depth of embedment (see information above) required. Do not over drill hole. Blow the hole clean of dust and other material. Insert the drop-in anchor into the hole and tap flush with surface. Using setting tool, set drop-in anchor by driving the tool into the drop-in anchor until the shoulder of the tool is seated against the drop-in anchor.

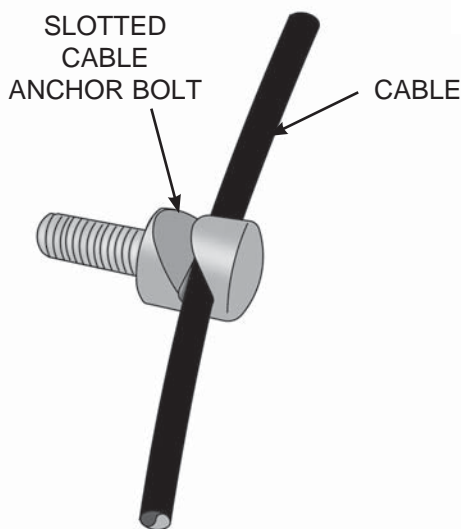
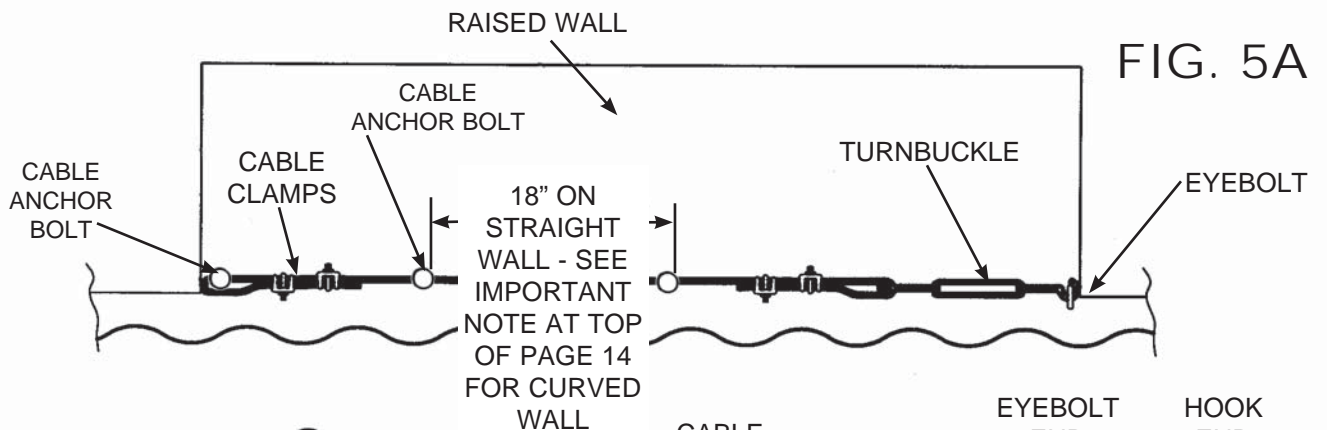

FIG. 5B

RUNNING CABLE THROUGH
 IN-LINE HOLES ON SLOTTED
 CABLE ANCHOR BOLTS

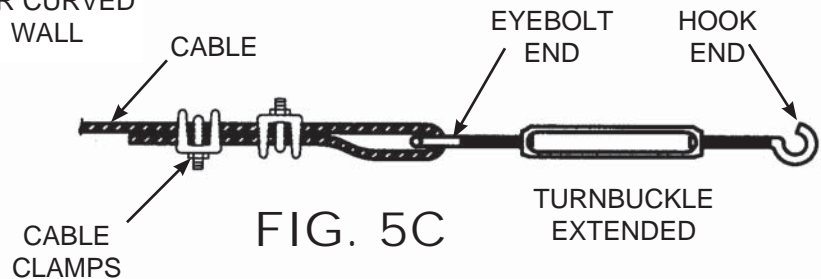

FIG. 5C

ATTACH CABLE TO EYEBOLT ON TURNBUCKLE

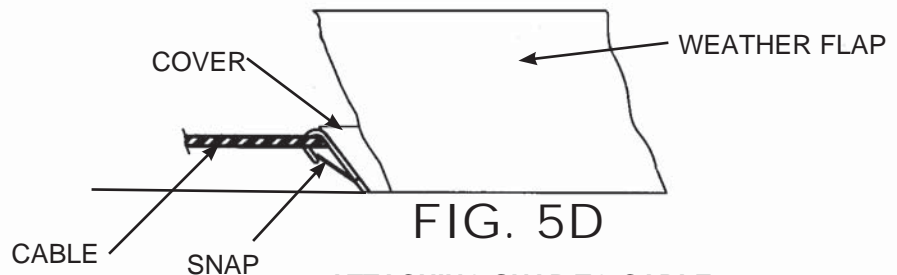

FIG. 5D

ATTACHING SNAP TO CABLE



Thank you for purchasing an Anchor product. In return, we pledge Quality, Service and Craftsmanship and are available for any questions you may have or assistance you may need.

PHONE NUMBER

812-867-2421

FAX NUMBER

812-867-1429

Anchor products are of superior design and operate best within the parameters of these instructions. It is **IMPERATIVE** that the instructions be carefully read and **COMPLETELY FOLLOWED**. Please read installation instructions before the installation or removal of this product. Installation instructions are also available at: www.anchorinc.com.

CAUTION

1. Anchor Products are of superior design and operate best within the parameters of these instructions. It is imperative that the instructions be carefully read and completely followed.
2. For each installation, the installer is solely responsible for evaluating the site for the proper securing methods and fasteners to be used. Standard fasteners furnished may be inadequate, site unseen by Anchor, thus requiring additional or alternate method of fastening.
3. Inasmuch as the weather is unpredictable, good judgment and common sense must be incorporated within installation guidelines. Proper safety equipment should be used at all times to insure a safe installation and removal. We suggest a careful evaluation be made to determine safety equipment needed, such as hard hats, steel-toe shoes, safety glasses and other as required.
4. Anchor stands behind its products in accordance with its standard Terms and Conditions of sale. A copy of our Terms and Conditions of Sale can be obtained by contacting Anchor at the telephone number and/or address on this document.



7701 Highway 41 N
Evansville, IN 47725
Phone: 812-867-2421
Fax: 812-867-1429
1-800-255-5552

email: custdiv@anchorinc.com
www.anchorinc.com