

PLAN VIEW

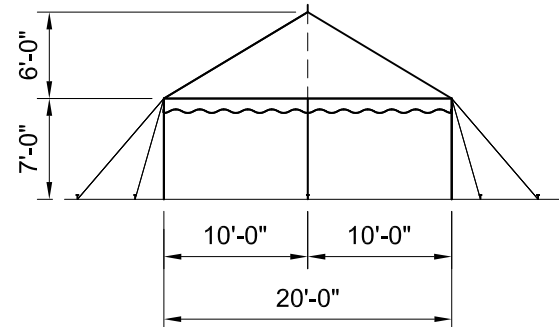

END ELEVATION

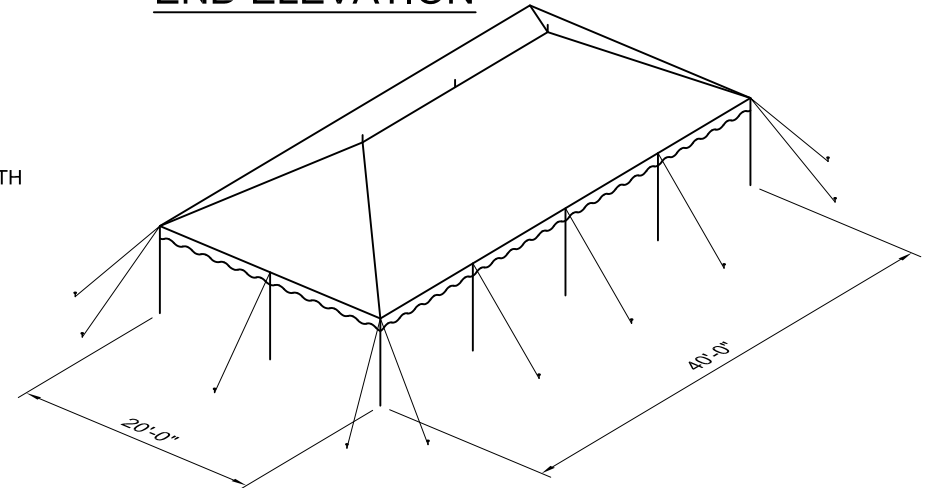

3D VIEW

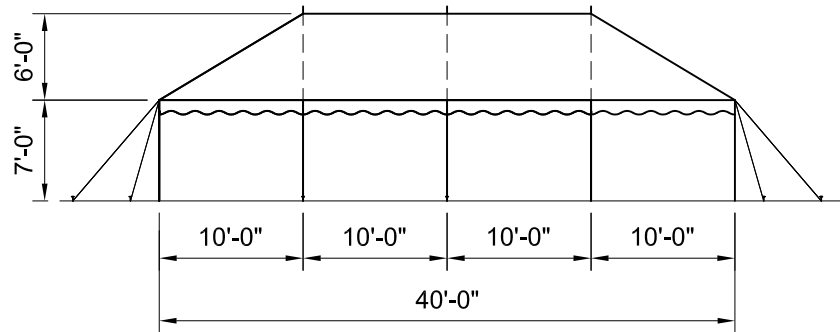

SIDE ELEVATION

NOTES:

1. SEE THE IFAI STAKING GUIDE ON OUR WEBSITE (WWW.ANCHORINC.COM) FOR SOIL IDENTIFICATION AND PULL-OUT CAPACITY OF STAKES.

ITEM DESCRIPTION		ITEM NO.
		<small>All data and information contained in or disclosed by this document is confidential and proprietary information of Anchor Industries, Inc. and all rights therein are expressly reserved. By accepting this material the recipient agrees that this material and the information contained therein is held in confidence and in trust and will not be used, copied, reproduced in the whole or in part, nor its contents revealed in any manner to others except to meet the specific purpose for which it was delivered.</small>
<p>PARTY MATE 20' x 40'</p> <p>SCHEMATIC</p>		
DRAWN BY:	DMK	CHECKED BY:
APPROVED BY:	EC#	DATE:
		10-26-12
REVISION HISTORY		DRAWING NO.
		12-369-5

REV	EC	DATE	BY
REVISION HISTORY			